

BATTERY CHARGING SYSTEMS

for Automatic Guided Vehicles



GENERAL INFORMATION

The operation of Automatic Guided Vehicles (AGVs) requires high utilization of these vehicles in order to achieve an optimum of profitability. Often, recharge of the batteries which are required for the drive of the AGVs, presents a problem.

The development of powerful batteries, which allow for quick recharge within seconds, enables the integration of charging contacts into the production cycle without removing the AGVs from the production process.

Battery charging stations may be installed anywhere within the system where the production process allows the AGV to stop (staging areas, turn arounds, loading stops etc.). Attention should be paid to attain best possible integration into a given layout.

VAHLE has developed special battery charging contacts which fully meet any requirement.

A battery charging contact consists of a base plate, which is installed on the floor or laterally at a bracket adjacent of the AGV runway, and a current collector which is installed on the vehicle.

A battery charger supplies current to the base plate. Once the AGV is in charging position and the collector has made contact with the base plate, the AGV computer turns on the current.

The base plate has chamfered entry/exit ramps to facilitate smooth drive-on/drive-off of the spring loaded collector. Bristle brushes installed on the collector remove debris from the base plate.

VAHLE battery operating charging contacts are designed for an voltage of 24 - 84 V. Nominal voltages > 25 V AC or 60 V DC require a protection against accidental touch.

AGVs serve as transportation vehicles and mobile assembly platforms. They connect assembly areas with assembly lines, service AS/AR installations etc.

The great variety of possible applications often requires custom designed AGVs with very specific demands for battery charging contacts.

A selection of our wide range of battery charging contacts is shown on the following pages.

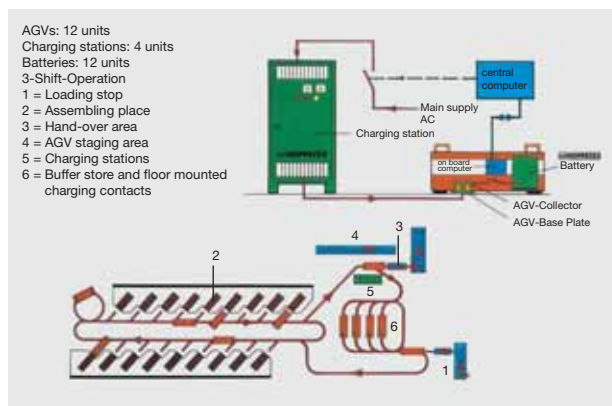

Schematic layout of power supply for Automatic Guided Vehicles (AGVs)



AGV-Collector - 2-phase, 200 A

Insulated collector for vehicle installation, with two contact brushes and a bristle cleaning brush.

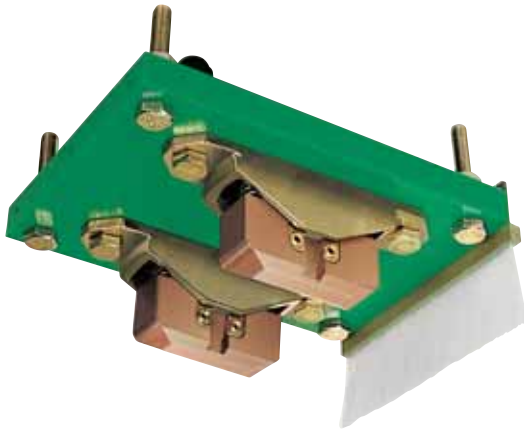

Type	Weight/kg	Cat.-No.
BLS 200-2-01	2.600	590 000

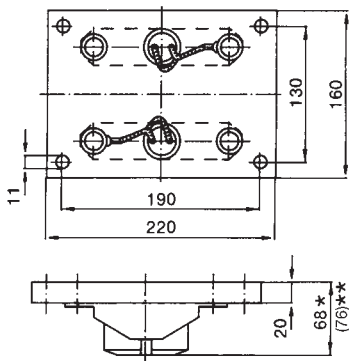

AGV-Base Plate

Insulated floor contact plate with two copper contact plates.



Type	Weight/kg	Cat.-No.
BLK 200-2-01	2.200	590 001

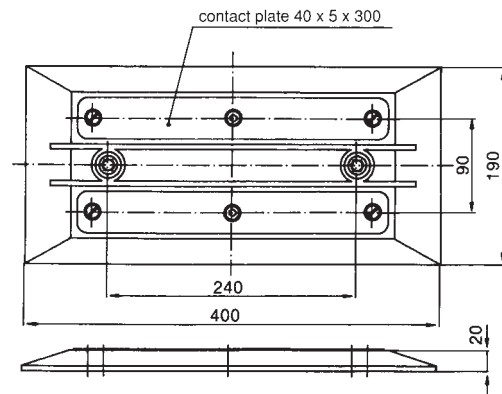

AGV-Collector - 2-phase, 200 A

Insulated collector for vehicle installation, with two contact brushes, surrounding bristle cleaning brushes and two-directional drive-on capability.

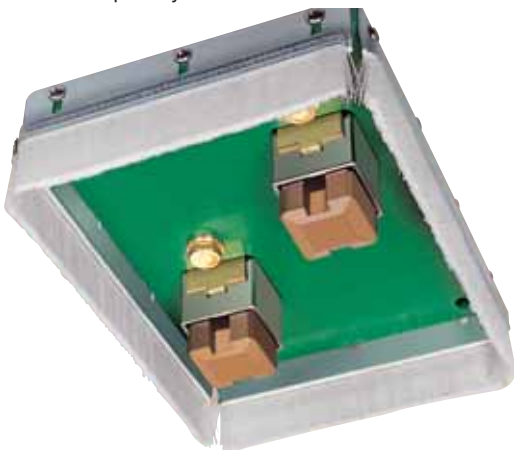

Type	Weight/kg	Best.-Nr.
BLS 200-2 Q-01	3.500	590 013

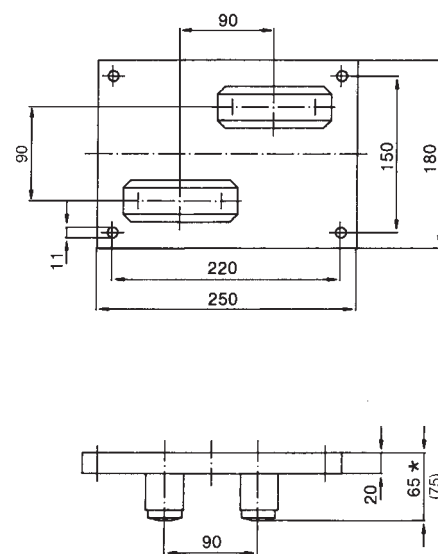

* height at contact position
 ** Dimensions in parantheses apply to released contacts



MODELS

AGV-Collector - 2-phase, 200 A

Insulated collector for vehicle installation, with two contact brushes each for charging, two pilot contacts and a bristle cleaning brush

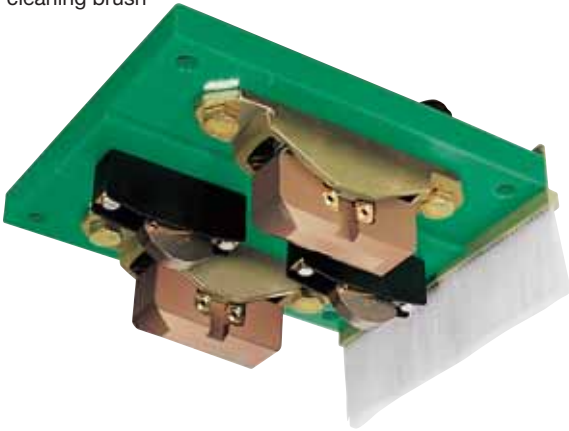

Type	Weight/kg	Cat.-No.
BLS 200-2/20-2-01	3.000	590 198

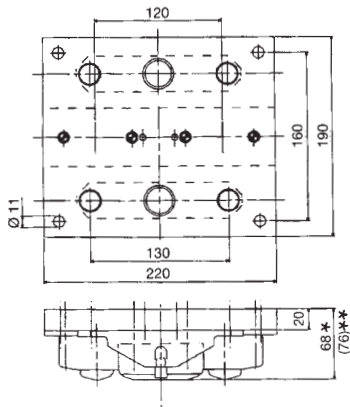

AGV-Base Plate

Insulated Floor contact plate with two copper contact plates for charging and two pilot copper contact plates.



Type	Weight/kg	Cat.-No.
BLK 200-2/25-2-01	2.700	590 062

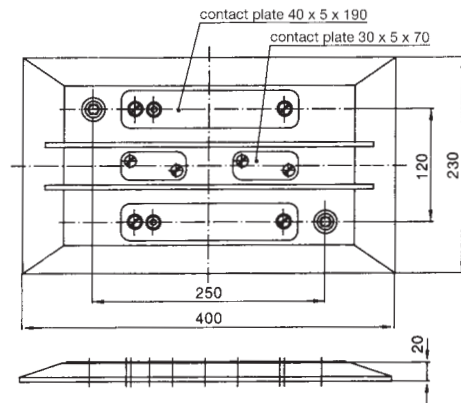

AGV-Collector - 2-phase, 20 A

Insulated collector for vehicle installation, with two contact brushes

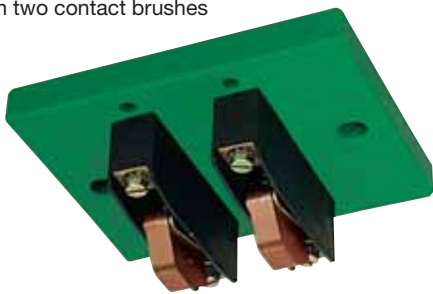

Type	Weight/kg	Cat.-No.
BLS 20-2-01	0.500	590 207

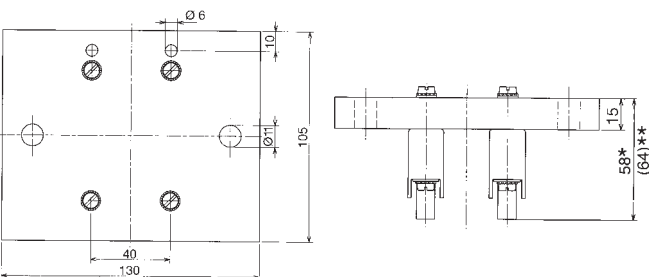

AGV-Base Plate

Insulated Floor contact plate, with two copper contact plates.

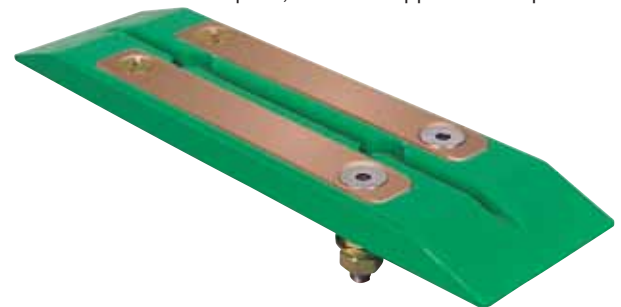

Type	Weight/kg	Cat.-No.
BLK 25-2-01	0.700	590 042

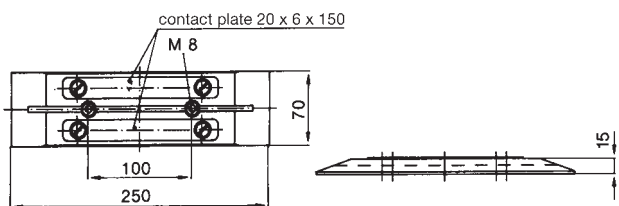

AGV-Collector - single phase, 200 A

Insulated collector for vehicle installation, with one contact brush and one bristle cleaning brush (to be used in pairs).



Type	Weight/kg	Cat.-No.
BLS 200-1-01 W	1.300	590 035

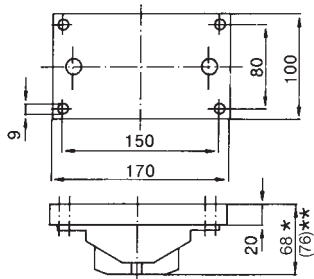

AGV-Base Plate

Insulated Floor contact plate, complete with single copper contact.



Type	Weight/kg	Cat.-No.
BLK 200-1-01 W	1.000	590 036

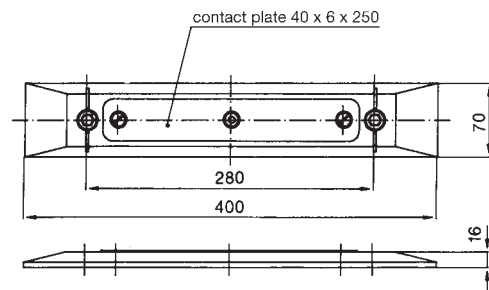

AGV-Collector - single phase, 600 A

Insulated collector for vehicle installation, with three contact brushes and one bristle cleaning brush (to be used in pairs).

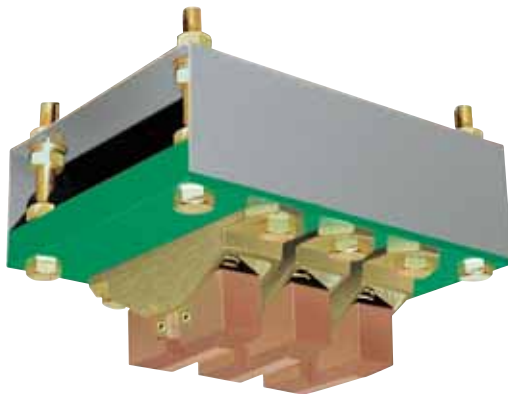

Type	Weight/kg	Cat.-No.
BLS 600-1 A-01	4.100	590 043

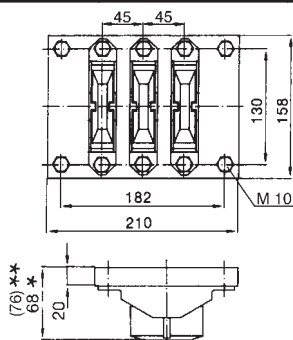

AGV-Base Plate

Insulated Floor contact plate, complete with single copper contact.

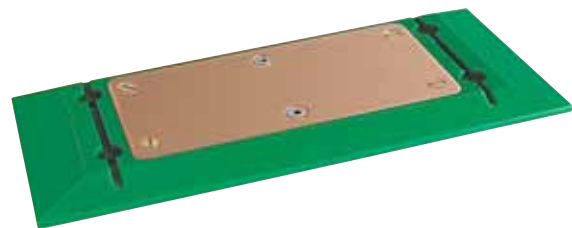

Type	Weight/kg	Cat.-No.
BLK 600-1-01	3.000	590 044

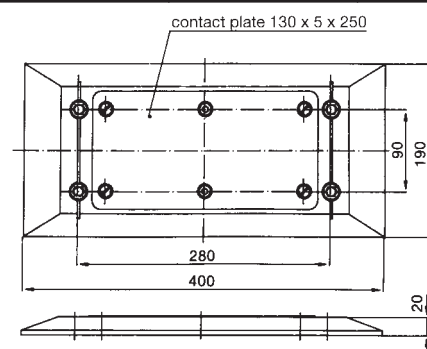

* height at contact position
 ** Dimensions in parantheses apply to released contacts



MODELS

AGV-Collector - 2-phase, 200 A

Insulated collector for vehicle installation, with two contact brushes and cover pusher.

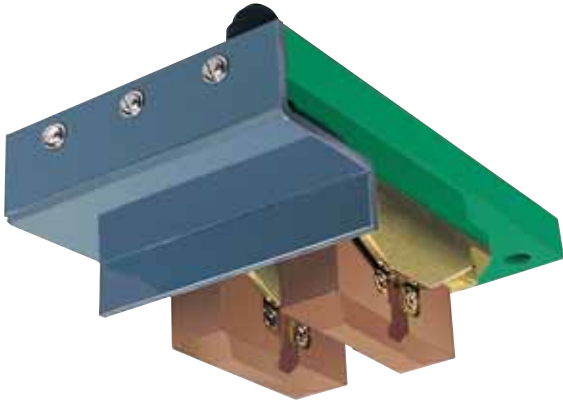

Type	Weight/kg	Cat.-No.
BLS 200-2 E-01 M	2.400	590 065

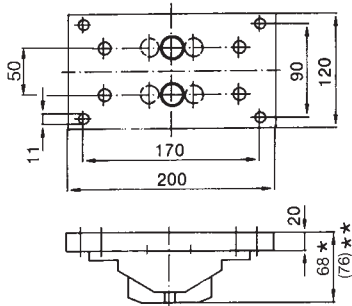

AGV-Base Plate

Insulated Floor contact plate with two copper contacts, spring loaded cover and 2 x 2 m connecting cables.



Type	Weight/kg	Cat.-No.
BLK 200-2 EA-02 M	3.900	590 064

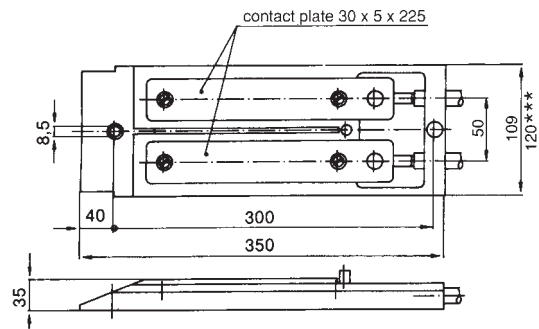

AGV-Collector - 2-phase, 200 A

Insulated collector for vertical installation on the battery charger, with two contact brushes



Type	Weight/kg	Cat.-No.
LST 200-2 E-01 J	36.000	590 060

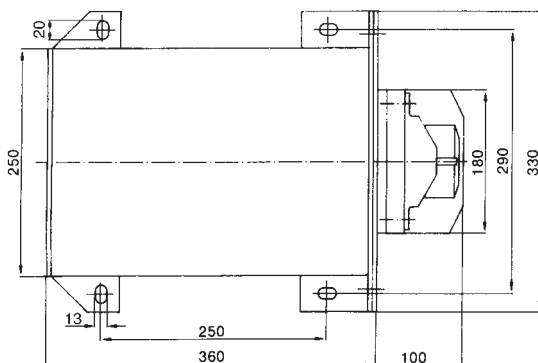

AGV-Base Plate

Insulated contact plate for vertical installation on side of vehicle, with two copper contacts.

Type	Weight/kg	Cat.-No.
BLK 200-2-01 J	2.300	590 014

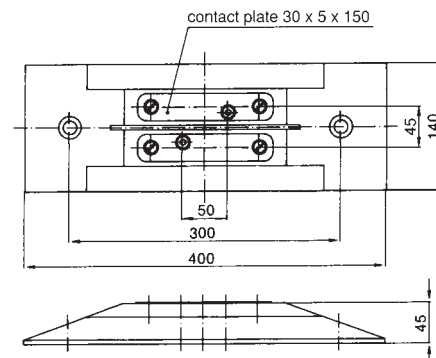

- Install AGV-collectors on vehicle with bristle cleaning brushes in direction of travel.
- Install AGV-Base Plate on top of the floor
- The *marked height 68 (65, 45) of AGV-Collectors type BLS is the dimension at contact position.
Allowable tolerance: + 2 mm.

In order to guarantee sufficient contact pressure the max. wear reduction of the contact brushes is limited to 5 mm whereby the unevenness of the floor must be considered.

- Between base plate and cutout at concrete floor a dust- and waterproof sealing has to be installed.

Example of installation BLS 200-2-01 with BLK 200-2-01

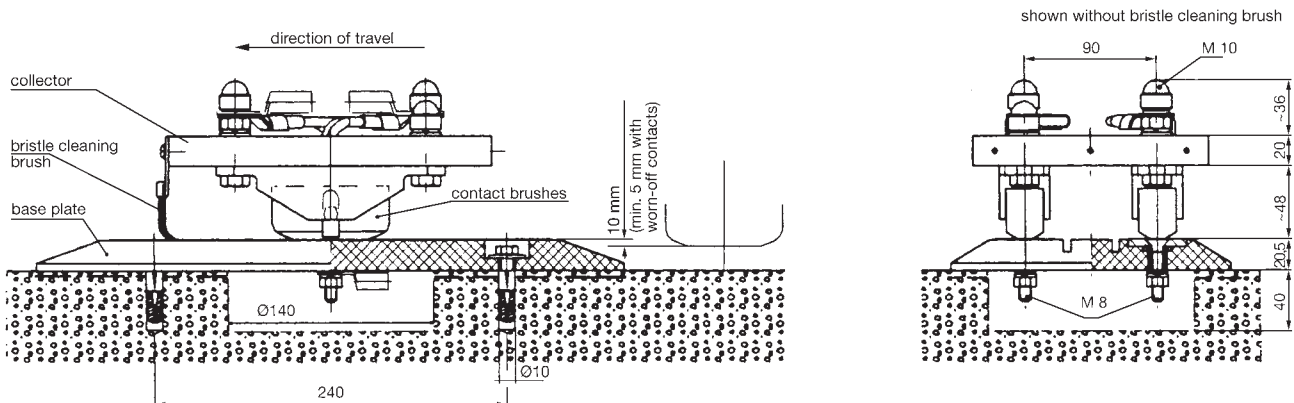

* consider unevenness of Floor when setting clearance for contact brushes
 --- install sealing at concrete cutout.



DQS certified in accordance with DIN EN ISO 9001:2000
OHSAS 18001 (Reg. no. 003140 QM OH)

Catalog No.

Copperhead Conductor Systems	1 a
Battery Charging Systems	1 b
Insulated Conductor Systems U 10	2 a
Insulated Conductor Systems U 20 – U 30 – U 40	2 b
Insulated Conductor Systems U 15 – U 25 – U 35	2 c
Aluminium Enclosed Conductor Systems LSV – LSVG	3 a
Powerail Enclosed Conductor Systems KBSL – KSL – KSLT – KSG	4 a
Powerail Enclosed Conductor Systems VKS – VKL	4 b
Powerail Enclosed Conductor System MKLD – MKLF – MKLS	4 c
Powerail Enclosed Conductor System KS-10	4 d
Powerail Enclosed Conductor System KBH	4 e
Heavy Enclosed Conductor Systems	5
Trolley Wire and Accessories	6
Cable Tenders	7
Cable Carriers for □-tracks	8 a
Cable Carriers for Flatform Cable on I-beams	8 bF
Cable Carriers for Round Cable on I-beams	8 bR
Cable Carriers for ◇-tracks	8 c
Conductor Cables and Fittings	8 L
Spring Operated Cable Reels	9 a
VAHLE POWERCOM® – Data Transmission Systems	9 c
CPS® – Contactless Power Supply	9 d
SMG – Slotted Microwave Guide	9 e
WCS – Position Encoding System	9 f
Motor Powered Cable Reels	10

